

## COHERENT INTERACTION LENGTH OF LIGHT WAVES IN A NONLINEAR MEDIUM

S. A. AKHMANOV, A. I. KOVRIGIN, R. V. KHOKHLOV, and O. N. CHUNAEV

Moscow State University

Submitted to JETP editor April 28, 1963; resubmitted July 24, 1963

J. Exptl. Theoret. Phys. (U.S.S.R.) **45**, 1336-1343 (November, 1963)

An experimental investigation is performed of the factors determining the coherent interaction length of light waves when optical harmonics are generated by passing light from a ruby laser through crystals having nonlinear polarizability. It is shown that mean coherent lengths  $\bar{l}_c \approx 0.5$  cm can be obtained. It is also shown that the restrictions on the divergence of laser beams are very rigorous for large values of  $l_c$ . This results in very different maximum efficiencies of power and energy conversion in experiments on optical harmonic generation. An extra amplitude modulation of the harmonic radiation is noted, which probably results from fluctuations in the angular distribution of energy during a ruby laser pulse. The angular distributions of the harmonic and fundamental light beams are compared. The possibility of increasing  $l_c$  by employing an optical resonator is discussed briefly.

## 1. INTRODUCTION

THE recently discovered nonlinear effects accompanying the passage of intense light waves through solids, liquids, and gases have been subjected to many experimental and theoretical investigations. Although the generation of optical harmonics<sup>[1-9]</sup> was the first nonlinear effect registered experimentally (while the list of experimentally observed effects now includes several others such as "optical detection" in transparent crystals,<sup>[10]</sup> the summing of coherent and incoherent light frequencies,<sup>[11]</sup> difference-frequency generation in crystals<sup>[12]</sup> etc.) and this effect was studied in great detail, the previous experimental studies have not exhausted the subject.

The first experiments<sup>[1-4]</sup> were performed with a focused beam of the fundamental frequency, so that appreciable nonlinear interactions of the light waves occurred in a small volume of the medium similar in dimensions to the focal spot and "local" nonlinear effects were investigated. Subsequent work<sup>[5,6]</sup> demonstrated the possibility of obtaining appreciable nonlinear effects in unfocused beams. Relatively low electric fields are here compensated for by the possibility of accumulating nonlinear effects over large distances. This is a promising direction of nonlinear optical research.

Although many features of accumulated nonlinear optical effects are accounted for satisfactorily by the current theory of waves in nonlinear media,<sup>[7-9]</sup> the theory is inadequate in several important aspects. Indeed, while interactions between un-

modulated plane waves were considered in<sup>[7-9]</sup>, the investigation of interacting modulated waves was discussed only in<sup>[13]</sup>. On the other hand, the light emitted by solid lasers, which are ordinarily employed in nonlinear optics, is strongly modulated, resulting in nonplane waves. The field of one of these lasers is

$$E = \sum_{i=1}^n A_i(t) \cos [\omega_i t - \mathbf{k}_i(t) \mathbf{r} + \varphi_i], \quad (1)$$

where  $A_i(t)$  are functions of time (random functions at room temperature) describing the amplitude modulation ("peaks") of the laser,  $\omega_i$  are frequencies of different laser modes, and the function  $\mathbf{k}(t)$  represents frequency and direction changes of laser radiation during a pulse. The role of laser modulation (especially the modulation of  $\mathbf{k}$ ) obviously plays an increasingly important part in the experimental generation of harmonics as the nonlinear interaction length is increased.

The present paper describes experimental work performed to produce nonlinear interactions of light waves in crystals over great lengths and to study the properties of these (accumulated) interactions that are associated with the modulation of laser oscillations. We investigated the second harmonic excited by a ruby laser in crystals of KDP (potassium dihydrogen phosphate) and ADP (ammonium dihydrogen phosphate). The spatial distribution of the harmonic was studied in addition to the power and energy.

## 2. EXPERIMENTAL APPARATUS AND PROCEDURE

Figure 1 is a block diagram of the apparatus. The ruby laser light is extracted from the resonator with the aid of a plane parallel plate or semi-transparent mirror and is directed to the working crystal. In order to obtain an accumulated effect the crystal is oriented relative to the laser beam in such a way that the phase velocity of the extraordinary second harmonic wave equals the phase velocity of the ordinary fundamental wave (along the so-called "direction of synchronism,"<sup>[5-9]</sup>). The harmonic was indicated either by means of a photomultiplier (at the exit of the mirror monochromator, which was further shielded from the laser fundamental by a filter that was transparent to the investigated harmonic) and a pulsed oscillograph, or directly on a photographic plate (when investigating the spatial distribution).

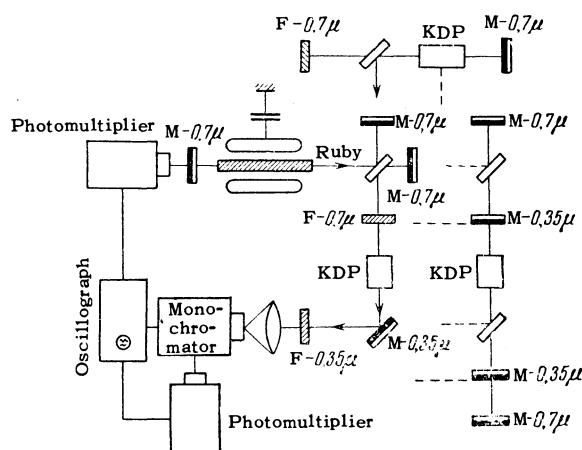

FIG. 1. Block diagram of apparatus for observing optical harmonics. The maximum wavelengths transmitted by the filters F and reflected by the mirrors M are indicated.

The KDP and ADP crystals employed in our experimental work were cut in the form of rectangular prisms and were oriented along the "direction of synchronism." The crystals were installed in a special optical goniometer which oriented them accurately (to within 30") relative to the laser beam.

The power of the harmonic was measured absolutely by comparison with the lines of a standard mercury lamp, and the laser energy was measured calorimetrically.<sup>1)</sup> Relative power measurements were performed using a specially calibrated photoelectric arrangement.

<sup>1)</sup>The authors are indebted to V. S. Zuev, who was consulted regarding the technique of absolute energy measurements.

The ruby rods used in the experiment were cut at 90° to the optic axis. The orientation of the ruby rod and of the crystal with nonlinear polarizability was such that the laser beam was polarized in a plane perpendicular to the principal plane of the KDP crystal. The laser radiation then excited an ordinary wave in the crystal, and the second harmonic ( $\lambda_2 = 3467 \text{ \AA}$ ) had maximum power. A  $\text{CuSO}_4$  solution was found to be the most suitable filter for discriminating the second harmonic of the ruby laser in studying its spatial and time distributions.

In all experimental work special means have been employed to filter the emission of the laser pumping lamp; in the case of the ruby laser a red glass filter was used.

It is known<sup>[7,8]</sup> that the power  $P_2$  of the second harmonic rises monotonically with increasing distance  $l$  while

$$l \leq l_c = \lambda_1/4(n_2 - n_1) \equiv \lambda_1/4\Delta n. \quad (2)$$

Here  $\lambda_1$  is the wavelength of the fundamental frequency;  $n_1$  and  $n_2$  are the refractive indices of the crystal for the fundamental and second harmonic frequencies. The quantity  $l_c$  is called the coherent interaction length. For  $l \leq l_c$  and  $P_2 \ll P_1$ , where  $P_1$  is the power of the fundamental frequency, we have<sup>[7,8]</sup>

$$P_2 = \frac{\chi' \pi}{\lambda_1} l^2 P_1^2 \quad (3)$$

where  $\chi'$  is the corresponding component of the nonlinear polarization tensor.

In accordance with the foregoing we used the following procedure to obtain an experimental value of the coherent interaction length. At constant laser power (controlled photoelectrically) numerous absolute measurements of second harmonic power were obtained, corresponding to different orientations of the KDP or ADP crystal relative to the laser beam.

For an arbitrary orientation of the crystal relative to the laser beam different refractive indices were observed for the ordinary and extraordinary waves having frequencies in a 1:2 ratio. Thus with the crystal oriented along the principal optic axis we have  $\Delta n \approx 0.03$ , so that from (2) the minimum coherent interaction length in the KDP crystal is  $l_{c \text{ min}} \approx 10^{-3} \text{ cm}$ . When the crystal is oriented in the "direction of synchronism" we have  $\Delta n \rightarrow 0$  and  $l_c$  increases.

In our measurements we usually used two power readings for the second harmonic corresponding to the same laser power:  $P_{2 \text{ min}}$  corresponding to  $l_{c \text{ min}} \approx 1.5 \times 10^{-3} \text{ cm}$ , and  $P_{2 \text{ max}}$  corresponding

to crystal orientation along the "direction of synchronism." When the change of  $\chi'$  accompanying a change of crystal orientation is insignificant (in actuality the maximum change of the angle between the principal optic axis and the laser beam did not exceed  $\sim 10-15^\circ$ ) we have

$$P_{2\max}/P_{2\min} = l_{c\max}^2/l_{c\min}^2, \quad (4)$$

from which  $l_{c\max}$  is evaluated.

In order to exclude errors associated with spatial beats of the power  $P_2$  in a crystal having the usual working length  $l \gg l_{c\min}$ ,  $P_{2\min}$  was determined from numerous measurements corresponding to somewhat different crystal orientations.

### 3. EXPERIMENTAL RESULTS

**A. Mean coherent interaction length and harmonic power.** We used a ruby laser with mean power output 1–5 kW operating at room temperature. Since the light from a ruby laser shows strong amplitude modulation ("peaks") the determination of  $l_c$  by the procedure described in Sec. 2 was performed for each pair of corresponding peaks of the second harmonic and the fundamental frequency,  $P_{2i}$  and  $P_{1i}$  (where  $i$  is the serial index of the peak). It must be noted that the values of  $l_c$  determined in this manner are highly scattered from peak to peak; we do not believe that this effect can be attributed to measurement errors alone. The scattering is graphically illustrated in Fig. 2.

We thus arrive at the obvious conclusion that the coherent interaction length is of random magnitude and can be represented by<sup>2)</sup>

$$l_{ci} = \bar{l}_c + \Delta l(i), \quad \overline{\Delta l(i)} = 0.$$

In some instances the magnitude of the relative fluctuations of  $l_c$ , especially for great lengths of the KDP crystal, was given by

$$\sqrt{\overline{\Delta l_i^2}}/\bar{l}_c \approx 0.5.$$

When the crystal was oriented along the "direction of synchronism" typical mean coherent interaction lengths were  $\bar{l}_c \approx 0.5$  cm and were close to the working lengths of the corresponding crystals. Typical values of  $P_{2\min}$  and  $P_{2\max}$  are

No. of run	1	2	3	4	5
$P_{2\min}$ , W:	$10^{-8}$	$6 \cdot 10^{-9}$	$2 \cdot 10^{-8}$	$3.1 \cdot 10^{-8}$	$7.5 \cdot 10^{-9}$
$P_{2\max}$ , W:	$2 \cdot 10^{-3}$	$4 \cdot 10^{-3}$	$7 \cdot 10^{-3}$	$2 \cdot 10^{-3}$	$8 \cdot 10^{-3}$

<sup>2)</sup>Fluctuating departures from (3) can also be described in terms of extra fluctuations of the second harmonic amplitude that are not determined only by fluctuations of the fundamental amplitude.

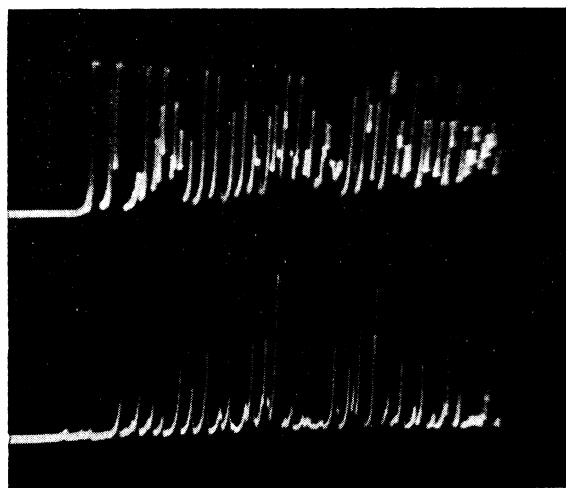

FIG. 2. Oscillograms of the pulse envelope. Fundamental frequency  $\lambda_1 = 0.7\mu$  (above) and second harmonic  $\lambda_2 \approx 0.35\mu$  (below) generated in a KDP crystal 2 cm long that was oriented relative to the fundamental beam so that  $\Delta n \leq 10^{-4}$ .

In individual runs the maximum power of the second harmonic reached  $\sim (1-2) \times 10^{-2}$  W.

When  $\bar{l}_c \approx 1$  cm the angular accuracy with which the laser beam direction and the "direction of synchronism" must coincide is extremely high. In our work when the angle  $\theta$  (measured from the principal optic axis) changed by  $3-5'$  relative to the angle of synchronism  $\theta_1 = 50^\circ$ , the power of the second harmonic was reduced one-half. It was therefore of decided interest to perform a direct experimental investigation of the spatial distribution of the second harmonic.

**B. Spatial distribution of the second harmonic.** The spatial distribution was investigated under operating conditions with maximum values of the power  $P_2$ . The laser beam first passed through a diaphragm, and the radiation leaving the KDP crystal went directly to a photographic plate.

Figure 3 is a photographed cross section of a second harmonic beam generated in a KDP crystal 2 cm long under excitation by an unfocused ruby laser beam. The angle  $\theta$  varies from left to right, and the azimuthal angle  $\varphi$  increases in the upward direction. The maximum power  $P_2$  is found at  $\theta_0 = 50^\circ$  and  $\varphi_0 = 45^\circ$ . The characteristic asymmetry of  $P_2(\theta)$  is very clear: the decrease of  $P_2$  for  $\theta > \theta_0$  is considerably slower than for  $\theta < \theta_0$ ;  $P_2(\varphi)$  varies considerably more slowly.

The foregoing is easily confirmed by comparing Fig. 3 with the photographed cross section of a laser beam (Fig. 4) emerging from the KDP crystal at the same point as the photograph in Fig. 3. A comparison of the two figures shows that the divergence of the harmonic beam in the  $\theta$  direction is considerably smaller than that of the ruby laser



FIG. 3. Photograph of the cross section of a second harmonic beam excited by an unfocused ruby laser beam in a KDP crystal 1 cm long.

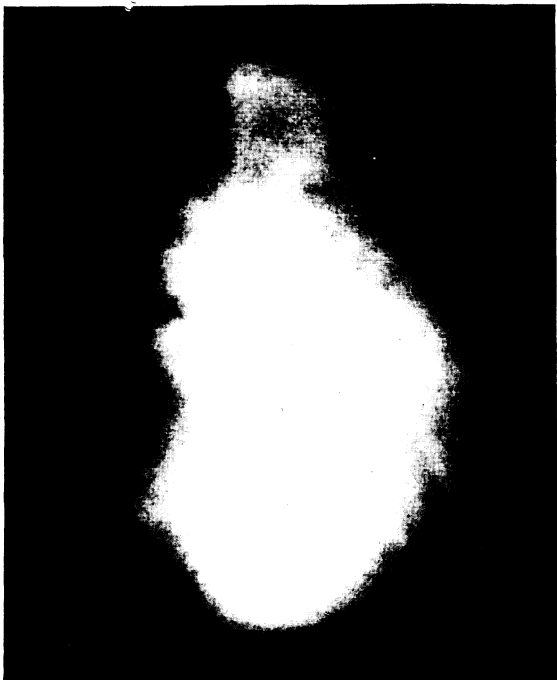

FIG. 4. Photograph of the cross section of a ruby laser beam (on the same scale as Fig. 3).

beam; the harmonic beam is better collimated. Mean divergence of the laser beam  $\Delta\psi \approx 20-25'$  is a typical result of our experiments. The divergence of the second harmonic beam for  $l \approx 2$  cm is  $\Delta\theta \approx 2-3'$  in the  $\theta$  direction and  $\Delta\varphi \approx \Delta\psi \approx 20-25'$  in the  $\varphi$  direction.

#### 4. DISCUSSION OF RESULTS

Our present experimental results furnish evidence that the optical harmonic generated by an unfocused laser beam under conditions of synchronism is a well-collimated beam. The divergence and uniformity of the beam for sufficiently large  $l_c$  present a considerably better picture than in the case of the fundamental laser frequency. This result is associated with the fact that for large  $l_c$  an effective contribution to the harmonic comes only from the components of the fundamental beam whose wave vectors are oriented very close to the direction of synchronism.

The asymmetric cross-sectional energy distribution of the harmonic beam with respect to  $\theta$  is easily understood from a consideration of the relation between the wave vectors of the fundamental and harmonic frequencies. From momentum conservation the combining of two photons of the fundamental frequency induces a field of twice the frequency with the wave vector  $k'_2$ :

$$k_1 + k_1 = k'_2. \quad (5)$$

When the conditions of synchronism are fulfilled  $k'_2 = k_2$ , which is the wave vector of the natural wave of the medium propagating in the direction determined by (5).

It is easily seen that the condition of synchronism for (5) can be fulfilled only when the refractive index  $n_1$  of the fundamental frequency exceeds that for the doubled frequency:<sup>[9]</sup>

$$n_1(\omega) > n_2(2\omega). \quad (6)$$

In a negative KDP crystal (6) is fulfilled for  $\theta > \theta_0$ ;  $\theta_0$  corresponds to the intersection between the refractive index ellipsoid of the second harmonic extraordinary wave and the refractive index sphere of the ordinary fundamental wave.

The causes of fluctuations in the coherent interaction length (of "extra" fluctuations of the second harmonic amplitude) are of considerable interest. The fluctuations can be associated with several factors:

1. With frequency changes from one peak of laser emission to another. Frequency changes lead to changes of the refractive index and therefore to temporal fluctuations of the coherent length.
2. With changes in the direction of the fundamental wave vector from one peak to another.
3. With fluctuations of the crystalline refractive index that are associated with fluctuations of laser power (owing to the cubic term in the expansion of polarization of the medium with respect to the field,

the refractive index depends on the field strength of the propagating wave).

4. With the fluctuating spread of phases in different laser modes.

Indeed, if in a single laser peak more than two equally-spaced modes are generated:

$$E_1 = \sum_{m=1}^n A_m(t) \cos [\omega_0(1 + m\Delta\omega)t + \varphi_m],$$

the amplitude of the second harmonic with the frequency  $2\omega_0 + 2m\Delta\omega$  is determined by the amplitudes and phases of the  $m$ -th,  $(m-1)$ -st, and  $(m+1)$ -st modes since the field of the second harmonic at this frequency is

$$E_2 \sim \frac{1}{2} A_m^2 \cos [2\omega_0(1 + m\Delta\omega)t + 2\varphi_m] + \frac{1}{2} A_{m-1} A_{m+1} \times \cos [2\omega_0(1 + m\Delta\omega) + \varphi_{m+1} + \varphi_{m-1}]. \quad (7)$$

Since  $\varphi_m$ ,  $\varphi_{m-1}$ , and  $\varphi_{m+1}$  are random phases, the resultant oscillation amplitude of  $E_2$  will also be random.<sup>3)</sup> It should be noted, however, that according to [14] the index  $m$  in a single peak usually does not exceed 2 or 3.

We believe that the most important source of fluctuations of  $l_C$  in our work was the fluctuating direction of the wave vector. In the KDP output for large  $l_C$  an appreciable contribution to the power of the second harmonic can come only from the laser modes having a suitable angular distribution. Thus with harmonics generated in long crystals the laser modes are selected in a special manner. The existence of this selectivity is confirmed by our spectral study of the second harmonic. Observations performed with a Fabry-Pérot etalon show that the clear discrete-line structure in the second harmonic spectrum can also be observed without using a sweep.

The more detailed investigation of extra fluctuations of the second harmonic amplitude goes beyond the limits of the present article; the results will be published subsequently. We note only that, as a result of these fluctuations, in experiments on the generation of optical harmonics the energy efficiency (Eff-E) does not equal the maximum value of the power efficiency (Eff-P<sub>max</sub>)

$$\text{Eff-E} < \text{Eff-P}_{\text{max}}.$$

Thus, further increase of the length  $l_C$  is accompanied by certain difficulties associated with the necessity of more precise orientation of the crystal and of improving the directionality of laser emission;  $\Delta\theta \approx 3'$  is still far from the diffraction limit of the laser.

It is not always possible to grow very homogeneous long crystals. It is therefore important to determine the possibility of increasing  $l_C$  by using an optical resonator tuned to the second harmonic. The arrangement of the appropriate experiment is shown on the right-hand side of Fig. 1. A calculation shows that a resonator tuned to the second harmonic, and transparent to the fundamental frequency, can increase the power output (for  $l < l_C$ ):

$$P_{2\text{res}}/P_2 = (1 - R)/(1 - \sqrt{R})^2, \quad (8)$$

where  $R$  is the power reflection coefficient of the resonator exit mirror. For our experimental setup the expected gain was  $\sim 50-60$ . However, the gain was actually relatively small (a factor of only a few) because of difficulties in adjusting the Fabry-Pérot etalon containing a KDP crystal mounted in the direction of synchronism and because of laser beam divergence.

Finally, another possibility of enhancing the transformation efficiency lies in placing the KDP crystal directly inside the ruby laser resonator (in the modification represented at the top of Fig. 1). The fact that the polarization planes of the harmonic and fundamental frequency are perpendicular enables us to extract the second harmonic alone from the resonator by means of a plane parallel plate.

We wish to acknowledge our indebtedness to I. S. Rez and L. I. Kuznetsova, who furnished the KDP and ADP crystals, and to N. K. Kulakova, A. K. Romanyuk, and M. M. Strukov for their assistance and useful discussions.

<sup>1</sup> Franken, Hill, Peters, and Weinreich, Phys. Rev. Letters 7, 118 (1961).

<sup>2</sup> Bass, Franken, Hill, Peters, and Weinreich, Phys. Rev. Letters 8, 18 (1962).

<sup>3</sup> Lax, Mavroides, and Edwards, Phys. Rev. Letters 8, 166 (1962).

<sup>4</sup> A. Savage and R. C. Miller, Appl. Optics 1, 661 (1962).

<sup>5</sup> J. Giordmaine, Phys. Rev. Letters 8, 19 (1962).

<sup>6</sup> Maker, Terhune, Nisenoff, and Savage, Phys. Rev. Letters 8, 21 (1962).

<sup>7</sup> R. V. Khokhlov, Radiotekhnika i elektronika 6, 1116 (1961).

<sup>8</sup> Armstrong, Bloembergen, Ducuing, and Pershan, Phys. Rev. 127, 1918 (1962).

<sup>9</sup> S. A. Akhmanov and R. V. Khokhlov, JETP 43, 351 (1962), Soviet Phys. JETP 16, 252 (1963).

<sup>10</sup> Bass, Franken, Ward, and Weinreich, Phys. Rev. Letters 9, 446 (1962).

<sup>3)</sup>We note that the difference frequencies corresponding to the second term in (7) have been observed experimentally.<sup>[12]</sup>

<sup>11</sup>A. W. Smith and N. Braslau, IBM J. Research  
Develop. **6**, 361 (1962).

<sup>12</sup>R. E. Niebuhr, Appl. Phys. Letters **2**, 136 (1963)

<sup>13</sup>S. A. Akhmanov and R. V. Khokhlov, Radiotekh-  
nika i élektronika **6**, 1813 (1961).

<sup>14</sup>Vanyukov, Isaenko, and Lyubimov, Optika i  
spektroskopiya **14**, No. 5 (1963).

Translated by I. Emin  
218