

A SUPERCONDUCTING INTERFEROMETER WITH RESISTIVE POINT CONTACTS

I. M. DMITRENKO, S. I. BONDARENKO, and T. P. NARBUT

Physico-technical Institute for Low Temperatures, Ukrainian Academy of Sciences

Submitted May 23, 1969

Zh. Eksp. Teor. Fiz. 57, 1513-1523 (November, 1969)

Formulas describing the main characteristics of a superconducting interferometer with two point contacts are derived on the basis of the theory of the Josephson effect. A comparison is made with experimental data obtained by investigating interferometers with point contacts of the S-S (superconductor-superconductor) and S-N-S (superconductor-normal metal-superconductor) types. A physical model of the resistivity of a contact and the conditions of maximum sensitivity of the interferometer to an external magnetic field are discussed.

In previous papers^[1, 2] we reported investigations of superconducting interferometers constructed by the method of Clarke.^[3] The important role of the difference in the resistance of the two interferometer contacts (the asymmetry of the interferometer) which leads to the detection of varying signals in the absence of a transport current through the interferometer and to other peculiarities was explained using such interferometers. Further investigations were carried out with interferometers prepared in accordance with a new method^[4] which made it possible to control accurately the area of the interferometer circuit and the position of the microcontacts, and to produce point contacts both of the S-S (superconductor-superconductor) and of the S-N-S (superconductor-normal metal-superconductor) type. For an analysis of the obtained data we have derived standard working formulas describing the behavior of the superconducting interferometer with two point contacts and based on the existing theory of the Josephson effect in tunneling junctions.^[5] The analysis of the experimental data carried out makes it possible to formulate the basic requirements essential for producing high-sensitivity instruments (in particular, a magnetometer) based on superconducting interferometers.

1. EXPERIMENT

Superconducting interferometers with S-S type contacts were prepared^[4] by micropuncturing of the oxide layer on Nb or Ta platelets with subsequent vacuum deposition of a tin film (Fig. 1). In order to obtain S-N-S type contacts after puncturing the oxide we deposited a 1300 Å silver film and then a tin film up to 6000 Å thick. The time between the puncturing operation of the oxide and the placing of the sample into the vacuum chamber amounted to several minutes. The deposition was carried out in a vacuum of 10^{-6} Torr. During the deposition of the silver and tin the substrate was cooled to about -100°C and after the tin was deposited it was immediately placed in a cryostat. The oxide on the niobium and tantalum was grown electrochemically; its thickness was determined very accurately.^[6] The punctures were produced on a special device by means of a steel needle and had a diameter of

1 to $10\ \mu$. The distance between the punctures was varied between 0.05 and 5 mm and the oxide thickness was varied between 40 and 4000 Å.

The interferometer, placed inside a solenoid, was shielded by a system of magnetic shields. The voltage V across the interferometer, the current through which was set by a circuit, was measured by means of a F116/1 microvoltmeter with an x-y recorder as a function of the transport current I or of the magnetic field H . The interferometer parameters varied were the area of the quantizing circuit (the thickness of the oxide and the distance between the contacts) and the resistance of the contacts in the normal state R which varied from 0.1 to 10 ohm at room temperature and from 8×10^{-3} to 3 ohm at 4.2°K .

2. THEORETICAL ANALYSIS OF THE INTERFEROMETER OPERATION

In order to analyze the operation of an interferometer, one must have formulas which describe the properties of a system in the form of a superconducting circuit with two superconducting point contacts connected in parallel in a magnetic field (Fig. 1). It will be shown below that these formulas can be obtained by transformation of an already known equation for the phase of a Josephson tunneling junction^[5] (a consideration of the

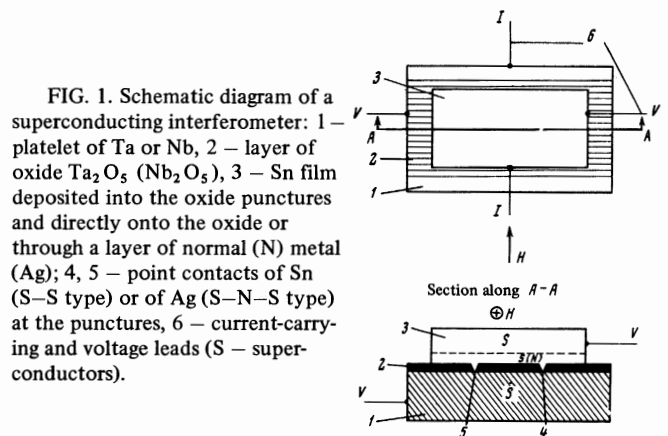

FIG. 1. Schematic diagram of a superconducting interferometer: 1 - platelet of Ta or Nb, 2 - layer of oxide Ta_2O_5 (Nb_2O_5), 3 - Sn film deposited into the oxide punctures and directly onto the oxide or through a layer of normal (N) metal (Ag); 4, 5 - point contacts of Sn (S-S type) or of Ag (S-N-S type) at the punctures, 6 - current-carrying and voltage leads (S - superconductors).

one-dimensional case does not change the final results):

$$\frac{\partial^2 \varphi}{\partial x^2} - \frac{1}{c_0^2} \left(\frac{\partial^2 \varphi}{\partial t^2} + \gamma \frac{\partial \varphi}{\partial t} \right) = \frac{1}{\lambda_j^2} \sin \varphi, \quad (1)$$

where φ is the phase difference at the junction; $\gamma = 1/R_1 C$ is the attenuation coefficient expressed in terms of the normal resistance of the junction R_1 and its capacitance C ; $\lambda_j = [\hbar c^2 / (16\pi e \lambda_L j_c)]^{1/2}$ is the Josephson penetration depth; $c_0 = \omega_0 \lambda_j = (2e I_C / \hbar c)^{1/2}$ is the Josephson plasma frequency; I_C is the critical current of the junction.

Making use of the small dimension of the junction and of an expansion of the phase in x , $\varphi(x, t) = \varphi(0, t) + C_1 x + \frac{1}{2} C_2 x^2 + \dots$, as well as of the Josephson relation between the phase and the magnetic field $\partial \varphi / \partial x = (4e \lambda_L / \hbar c) H$ and Maxwell's equation $\text{curl } \mathbf{H} = 4\pi \mathbf{j} / c$, one can find the boundary conditions for the magnetic field:

$$H(L^*) - H(0) = \frac{\hbar c}{4e \lambda_L} C_2 L^* = \frac{4\pi}{c} I_i, \quad (2)$$

$I_i = j L^*$ where L^* is the dimension of the junction along x . Hence we find

$$\frac{\partial^2 \varphi}{\partial x^2} = C_2 = \frac{16\pi e \lambda_L I_i}{\hbar c^2 L^*} = \frac{1}{\lambda_j^2} \frac{j}{j_c}, \quad (3)$$

and after simple transformations Eq. (1) is obtained in the form

$$\begin{aligned} \varphi + \gamma \varphi + \omega_0^2 \left(\sin \varphi - \frac{I_i}{I} \right) &= 0, \\ \varphi &= \partial \varphi / \partial t, \quad \ddot{\varphi} = \partial^2 \varphi / \partial t^2, \end{aligned} \quad (4)$$

which coincides with the equations obtained in [7, 8] when the displacement current $\sim \ddot{\varphi}$ is neglected.

In the case of a doubly connected superconducting interferometer with two contacts one must take into account the known condition [9] for the phase

$$\varphi_1 - \varphi_2 + 2\pi(\Phi / \Phi_0) = 2\pi n, \quad (5)$$

where φ_1 and φ_2 are the phase differences at the contacts, Φ is the total magnetic flux connected with the interferometer circuit, $\Phi_0 = hc/2e$ is the magnetic flux quantum, and n is an integer.

Furthermore, making use of Eq. (4) in the form

$$I_i = I_c (\sin \varphi + \gamma / \omega_0^2 \ddot{\varphi}), \quad (6)$$

which does not take into account the displacement currents, we write for the total current through the interferometer $I = I_1 + I_2$ where I_1 and I_2 are the currents through the interferometer contacts with resistances R_1 and R_2 respectively

$$I = I_{c1} \left(\sin \varphi_1 + \frac{\gamma_1}{\omega_{01}^2} \ddot{\varphi}_1 \right) + I_{c2} \left(\sin \varphi_2 + \frac{\gamma_2}{\omega_{02}^2} \ddot{\varphi}_2 \right). \quad (7)$$

From (5) and (7), introducing the notation $\varphi_1(t) + \pi \Phi / \Phi_0 = \psi(t)$, we obtain

$$I = I_{c1} \sin \left(\psi - \frac{\pi \Phi}{\Phi_0} \right) + I_{c2} \sin \left(\psi + \frac{\pi \Phi}{\Phi_0} \right) + \beta \ddot{\psi}, \quad (8)$$

where $\beta = (\hbar/2e)(R_1^{-1} + R_2^{-1})$. If one now makes the replacement $\psi(t) = \theta(t) + \alpha$ and α is taken from the condition*

$$\text{tg } \alpha = \frac{I_{c1} - I_{c2}}{I_{c1} + I_{c2}} \text{tg } \pi \frac{\Phi}{\Phi_0},$$

then expression (8) takes on the form

$$I = I_m(\Phi) \sin \theta(t) + \beta \dot{\theta}, \quad \dot{\theta} = \frac{2e}{\hbar} v, \quad (9)$$

where v is the instantaneous value of the voltage across the interferometer, and

$$I_m(\Phi) = \left[(I_{c1} - I_{c2})^2 + 4I_{c1}I_{c2} \cos^2 \pi \frac{\Phi}{\Phi_0} \right]^{1/2} \quad (10)$$

is the critical current of the interferometer.

For currents below the critical current, the stationary solution of (9) is of the form $\theta = \sin^{-1}(I/I_m)$ and $v = 0$.

For a symmetric interferometer $R_1 = R_2$, $I_{c1} = I_{c2} = I_c$, and, as is seen from (10), the modulation of the critical current by the magnetic flux reaches a maximum and the current has the usual form (see, for example, [9])

$$I_m(\Phi) = 2I_c |\cos \pi \Phi / \Phi_0|.$$

The current is in this case modulated to zero (Fig. 2a), whereas with increasing asymmetry of the interferometer ($R_1 \neq R_2$, $I_{c1} \neq I_{c2}$) the depth of the modulation decreases (Fig. 2b). The current maxima occur for values of the flux equal to an integral number of flux quanta $\Phi = n\Phi_0$ and the minima for $\Phi = (n + \frac{1}{2})\Phi_0$.

For currents larger than critical $|I| > I_m$ Eq. (9) has a solution of the form

$$\text{tg } \frac{\theta}{2} = \frac{I_m}{I} + \sqrt{1 - \left(\frac{I_m}{I} \right)^2} \text{tg } \frac{t\sqrt{I^2 - I_m^2}}{2\beta}, \quad (11)$$

the voltage $v(t) \neq 0$ and has a period

$$T_0 = 2\pi\beta / \sqrt{I^2 + I_m^2(\Phi)}, \quad (12)$$

the mean voltage measured in the experiments

$$V = \frac{\hbar}{2e} \bar{\theta} = \frac{\hbar}{2e} \frac{2\pi}{T_0} = R \sqrt{I^2 - I_m^2(\Phi)}, \quad (13)$$

where $R = R_1 R_2 / (R_1 + R_2)$.

On going over to a single contact the solutions and formulas presented take on, within the accuracy of the corresponding results of [7, 8], the form obtained by the other method.

The temperature dependence of the critical current

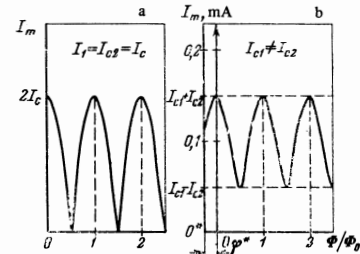

FIG. 2. Oscillations of the critical current of the interferometer calculated according to formula (10) for a symmetric (a) and asymmetric (b) interferometer for equal values of $I = I_{c1} + I_{c2}$ of a real Nb-Sn sample, $R = 0.22$ ohm, $T = 3.715^\circ \text{K}$. I_{c1} and I_{c2} are the critical currents of the contacts, φ^* is the phase shift connected with the asymmetry and with the magnetic field of the transport current [2].

* $\text{tg} = \tan$.

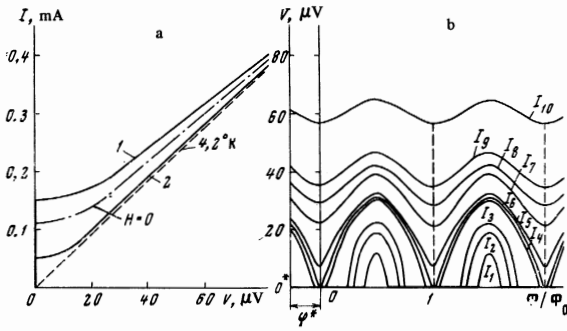

FIG. 3. Volt-ampere characteristics of an interferometer (a) plotted according to (13) for values of the critical current and resistance of a real sample: Nb-Sn, $R = 0.22$ ohm, $T = 3.715^\circ\text{K}$ (see Fig. 5a) for $1 - \Phi = n\Phi_0$; $2 - \Phi = (n + 1/2)\Phi_0$. The oscillations of $V(\Phi/\Phi_0)$ (b) obtained from the volt-ampere characteristics 1 and 2 for values of the transport current $I = 67, 97, 112, 148, 150, 155, 180, 200, 220, 300$ μA ; φ^* is the phase shift corresponding to the shift in Fig. 2b.

$I_c(T)$ and of the normal resistance $I_c(R)$ given for a Josephson tunneling junction by the formula^[10]

$$I_c(T, R) = \frac{\pi}{2} \frac{\Delta(T)}{eR} \text{th} \left[\frac{\Delta(T)}{2kT} \right], \quad (14)$$

can near T_c be represented by the formula

$$I_c(T, R) = \frac{\pi\Delta^2(T)}{4ekTR}, \quad (15)$$

which differs from the corresponding formula for point contacts of the S-S type of^[8] only by the factor $1/4$. Since we carried out the experiments mainly with S-S type point contacts, all the derivations and comparisons below will refer to interferometers with such contacts; the cases of S-N-S contacts will always be described separately.

In Fig. 3a we present the volt-ampere characteristics plotted in accordance with formula (13) for normal resistance values $R = 0.22$ ohm and critical currents at $T = 3.715^\circ\text{K}$ and $\Phi = n\Phi_0$ and $\Phi = (n + 1/2)\Phi_0$ corresponding to one of the interferometer samples based on Nb-Sn. The fact that curve 1 and the curve for $H = 0$ do not coincide is a result of the real asymmetry of the interferometer contacts which also leads to a phase shift φ^* of the oscillating part of the voltage $V(\Phi/\Phi_0)$ ^[21] plotted for various values of the transport current I in Fig. 3b.

Both the calculated and experimental dependences of the oscillation amplitude of $V(H)$ on the magnitude of the transport current are presented in Fig. 4.

Here it should be noted that the flux Φ is practically equal to the flux of the external field H if $LI_{c1\text{min}} < \Phi_0/2$ where L is the induction of the interferometer circuit and $i = 1, 2$; $\Phi = S_0H$. The samples investigated in this work with $L \sim 10^{-12} - 10^{-13}$ h satisfy this condition and considering the dependences $I(H)$ and $V(H)$ is equivalent to considering the dependences $I_m(\Phi)$ and $V(\Phi)$.

The following expressions for the amplitudes ΔI and ΔV of the oscillations of $I_m(H)$ and $V(H)$ with allowance for the asymmetry of the interferometer given by the coefficient $a = R_2/R_1 \geq 1$ follow from (10), (13), and

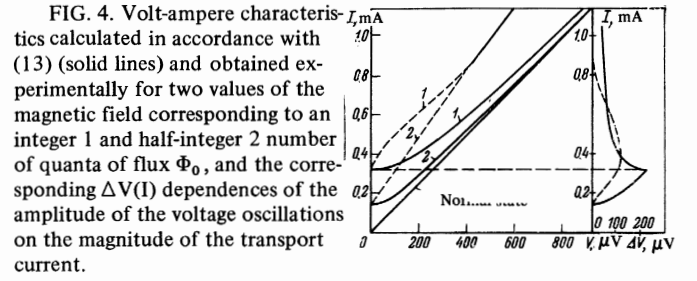

FIG. 4. Volt-ampere characteristics calculated in accordance with (13) (solid lines) and obtained experimentally for two values of the magnetic field corresponding to an integer 1 and half-integer 2 number of quanta of flux Φ_0 , and the corresponding $\Delta V(I)$ dependences of the amplitude of the voltage oscillations on the magnitude of the transport current.

(15); assuming for the sake of definiteness $R_2 \geq R_1$ and $I_{c2} \leq I_{c1}$, we have

$$\Delta I_m(T, a) = I_{m\text{max}} - I_{m\text{min}} = 2I_{c2} = A(T) \frac{2}{aI_1} \quad (16)$$

(we note that $\Delta I_m \sim 1/R_2$);

$$\Delta V(T, I, a)|_{I=I_{m\text{max}}} = \Delta V_m(T, a) = 2R \sqrt{I_{c1}I_{c2}} = A(T) \frac{2\sqrt{a}}{1+a} \quad (17)$$

[we note that $(\partial \Delta V_m / \partial R_i)_a = 0$, $i = 1, 2$] where

$$A(T) = \pi\Delta^2(T) / 4ekT.$$

In addition,

$$\Delta V = R\sqrt{I^2 - (I_{c1} - I_{c2})^2}, \quad \text{if } I_{c1} - I_{c2} < I < I_{c1} + I_{c2}$$

and

$$\Delta V \sim RI_{c1}I_{c2}/I, \quad \text{if } I \geq I_{c1} + I_{c2}$$

(see Fig. 4 on the right). It is seen from (16) and (17) that the temperature dependence of ΔI and ΔV is determined by the $I_c(T)$ dependence, and that with increasing asymmetry of the contacts the amplitude of the voltage oscillations decreases much more slowly than the amplitude of the oscillations of the critical current.

If $LI_{c1\text{min}} > \Phi_0/2$ then the modulation of the critical current decreases, becoming $\Delta I = 2i_{\text{circ}} = \Phi_0/L$ where i_{circ} is the current circulating in the interferometer circuit,^[21] and ceases to depend on the temperature (if the amplitude of the modulation is not limited by a strong asymmetry of the contacts).

The amplitude of the voltage oscillations also decreases by about a factor of $(I_c/\Delta I)^{1/2}$ and depends in the vicinity of T_c on the temperature as $[\Delta^2(T)/T]^{1/2}$ (in the case $a = 1$).

3. EXPERIMENTAL RESULTS AND DISCUSSION

The volt-ampere characteristics of the interferometer contacts produced by the method described above have the usual resistive non-hysteresis character which differentiates them from the volt-ampere characteristics of superconducting tunneling junctions. The magnetic field, by modulating the critical current, also modulates the volt-ampere characteristics with a period corresponding to a magnetic flux quantum in the cross section of the quantizing circuit (Fig. 5a) in accordance with (10) and (13).

Deposition of a film over the oxide layer produces a region having the properties of a band resonator. With an appropriate choice of the dimensions of the film one can obtain natural frequencies of the resonator in the microwave region. The Q of the resonator turns out to

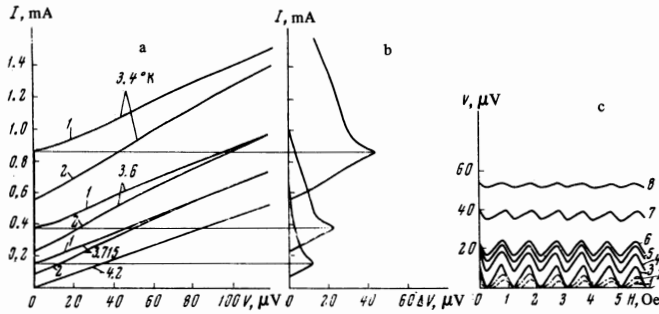

FIG. 5. Experimental volt-ampere characteristics of the interferometer (a) at various temperatures and two values of the magnetic field corresponding to 1 — $\Phi = n\Phi_0$, 2 — $\Phi = (n + \frac{1}{2})\Phi_0$ for the Nb-Sn sample, $R = 0.22$ ohm. Experimental $\Delta V(I)$ dependences at various temperatures (b). The form of the voltage oscillations $V(H)$ (c) for various values of the current I : 1 — 100; 2 — 110; 3 — 140; 4 — 180; 5 — 200; 6 — 220; 7 — 325; 8 — 400 μA for an Nb-Sn sample, $R = 0.22$ ohm, $T = 3.715^\circ K$.

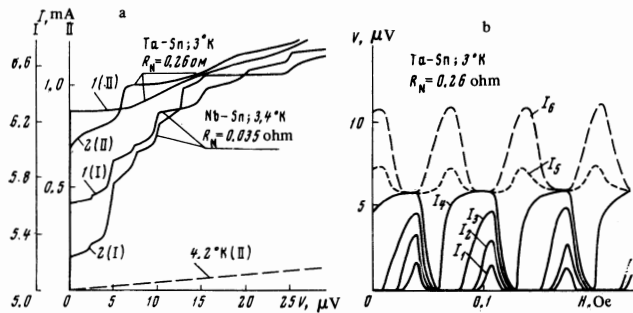

FIG. 6. Experimental "steplike" volt-ampere characteristics of two (I and II) interferometers for two values of the magnetic flux (a): 1 — $\Phi = n\Phi_0$, 2 — $\Phi = (n + \frac{1}{2})\Phi_0$. Form of the $V(H)$ oscillations of the interferometer II (b) for currents $I = 760, 800, 810, 820, 880,$ and $1000 \mu A$.

be sufficient for the appearance of self-synchronization of the point contact which in the presence of a potential difference across it freely generates high-frequency electromagnetic oscillations.^[11] As a result current steps (Fig. 6a) appear on the volt-ampere characteristics of a point contact, as in the case of a Josephson tunneling junction.

Deposition of a (1300 Å) silver film producing a S-N-S type point junction gives rise to no qualitative change in either the volt-ampere characteristic itself, nor in the current steps, nor in the interference pattern (Fig. 7). The magnitude of the critical current at all temperatures turns out to be considerably smaller (Fig. 8) compared to pure tin contacts with the same normal resistance R . The critical temperature is also lower and is $\sim 3.6^\circ K$ (for S-S type contacts it is $3.8^\circ K$). An increase of the T_c of the contacts connected with the proximity effect has been observed with samples of the Nb-Sn or Ta-Sn type. Therefore, when comparing the $I_c(T)$ and $I_c(R)$ dependences with formula (15) we took the value of $\Delta(T)$ to be the tin gap $\Delta_{Sn}(T)$. As is seen from Fig. 8, the agreement for $I_c(R, T)$ of S-S type contacts is quite good, but the critical current has values somewhat lower than the calculated values.

The quantum oscillations of the voltage $V(H)$ correspond qualitatively to the formulas obtained. The maxi-

mum of the amplitude ΔV corresponds to the current $I_{m\max}$ (Fig. 5). The nature of the $\Delta V(I)$ curve is close to that of the theoretical curve (Fig. 4) and the magnitude of ΔV_{\max} increases with decreasing temperature (Fig. 5).

The appearance of current steps on the volt-ampere characteristics changes the form of the $V(H)$ oscillations appreciably; there appears a characteristic flattening of the extrema (Figs. 6b and 7b), and the amplitude ΔV varies sharply in a narrow range of currents. The appearance of current steps is undesirable for magnetometric measurements and they should be suppressed by an appropriate choice of the sample geometry and an increase of the resistance of the contacts.^[1]

There are considerable discrepancies between the calculated and experimental values of the amplitude of the voltage oscillations. In Fig. 4 the dashed curve is taken from the experimental data of^[13] for clamped point contacts. The values of ΔV_{\max} for the contacts investigated in that work are by a factor of 2.5 smaller than the values which follow from the calculations. This is above all connected with the deviation of the volt-ampere characteristics from the theoretical ones. In the work of McCumber^[14] this discrepancy has been qualitatively removed by taking into account the induction of the contact. In this case the equation for the phase is solved only by numerical integration, and the corresponding volt-ampere characteristic has a slope which corresponds to the experimental one. The lack of an analytical expression for the volt-ampere characteristic unfortunately does not allow one to obtain more exact formulas analogous to (10) and (13). With decreasing temperature (increasing I_c) it is often possible to observe a change in the slope of the initial section of the volt-ampere characteristic and the appearance of hystereses which also follow from the considerations of McCumber and Stewart.^[14] Possibly the appearance of hysteresis of the volt-ampere characteristic is also connected with thermal effects, and its initial slope is determined to a considerable extent by fluctuations.^[15]

The question of the resistive state of the contacts for $I > I_c$ is of great physical interest in investigations of superconducting point contacts. It cannot be considered to be a purely normal state with the loss of the doubly-connected nature in the case of interferometers, as is assumed in^[16], since the volt-ampere characteristic for $I > I_c$ attests to the presence of a superconducting component of the currents (apparently up to values of V of the order of several magnitudes of Δ/e ^[17]), and the presence of quantum oscillations of the voltage attests to the fact that the density of superconducting electrons $n_s > 0$ remains finite everywhere in the quantizing circuit. Also, one cannot in general agree with the interpretation in terms of the motion of quantized vortex rings at the contact, since for the diameter of the contacts $d < \xi(T)$ this mechanism is impossible^[2] (ξ is the coherence length).

¹⁾ With increasing R the phenomenon of generation disappears before the quantum interference (for $R \sim 1$ ohm)^[12].

²⁾ Quantum interference is observed with normal resistances of the contacts between 10^{-3} and 10^2 ohm, i.e., for diameters of the order of $10^{-3} - 10^{-6}$ cm.

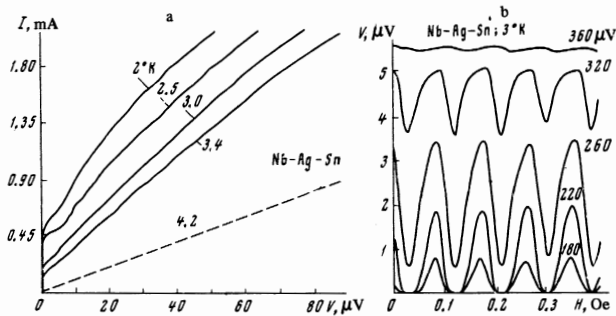

FIG. 7. Experimental volt-ampere characteristics of an interferometer with point contacts of normal metal (S-N-S type) (Ag thickness = 1300 Å) in a constant magnetic field $\sim 10^{-3}$ Oe and various temperatures (a). Form of the V(H) oscillations for the same interferometer with contacts of normal metal for various currents I, R = 0.1 ohm (b).

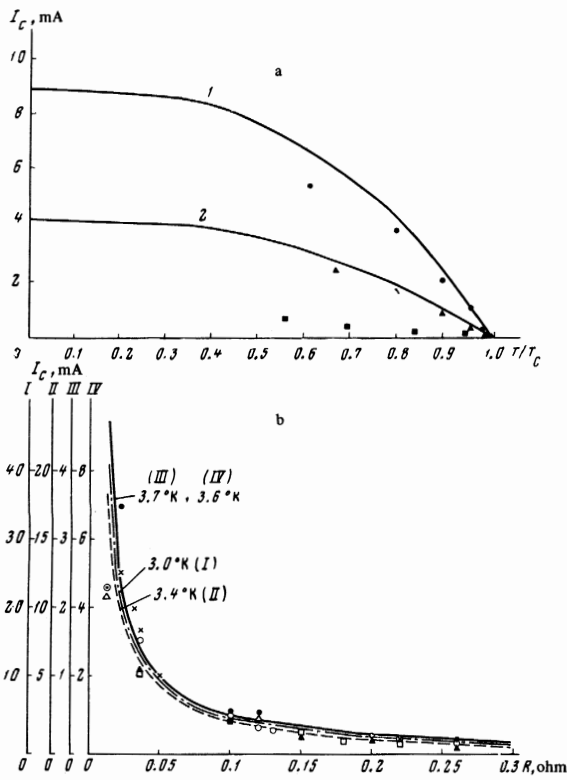

FIG. 8. Experimental points and theoretical curves (1 - R = 0.1 ohm for Ta-Sn; 2 - R = 0.22 ohm for Nb-Sn) of the dependences of the critical current I_c of superconducting point contacts of the S-S type on the reduced temperature T/T_c ; ■ - experimental values of I_c for an S-N-S point contact Nb-Ag-Sn (Ag thickness = 1300 Å), R = 0.1 ohm (a). Experimental points and theoretical curves of the dependences of the critical current of superconducting S-S type contacts on their normal resistance R at various temperatures (b). At 3.7°K ○ - Ta-Sn, ○ - Nb-Sn; at 3.6°K ● - Ta-Sn, X - Nb-Sn; at 3.4°K Δ - Ta-Sn, ▲ - Nb-Sn; at 3.0°K □ - Ta-Sn, ■ - Nb-Sn.

The induced current steps observed by Clarke^[19] on the volt-ampere characteristic of S-N-S type sandwiches and the observation of current steps and quantum interference in our interferometers with a silver layer (Fig. 7), as well as the form of the $I_c(T)$ dependence at test to the fact that the microscopic approach in terms

of the proximity effect taken in the work of Aslamazov and Larkin,^[7,8] is the most correct approach for point contacts. The appearance of a resistive state, regardless of the fact whether the contact itself is made of normal or superconducting metal, can be interpreted^[21] as a result of the nonlinear dependence of the superconducting current on the superfluid velocity^[20] and a decrease of the order parameter due to the action of the transport current I or the circulating current i_{circ} flowing in the circuit.

Preliminary experiments with interferometers whose weak links were in the form of tin "whiskers" of 1 μ diameter and 2-3 μ long showed the absence of quantum interference both in the critical currents and in the voltage. This gives grounds for assuming that the Josephson effects and the quantum interference are rather critical [$l \leq \xi(T)$] to the length l (along the current) of the region of weak coupling with a lowered value of the order parameter than to the cross section of this region. A lowering of the parameter n_1 can be achieved by means of the contact material or by the proximity effect, as well as by a local increase of the temperature or of the current density.

In conclusion we shall summarize the conclusions concerning the construction of an optimal superconducting interferometer with a maximum sensitivity to a magnetic field. First of all, it follows from (16) and (17) that it is more convenient to use an interferometer in the resistive regime, since it is less sensitive to asymmetry. In order to obtain a maximum sensitivity of the interferometer $\Delta V/\Delta H$ (or $\Delta I/\Delta H$) where $\Delta H = \Phi_0/S_0$ - the period of the oscillations for a circuit area S_0 , one must ensure the following:

1. The symmetry of the contacts, i.e., $a = 1$.
2. A maximum value of $\Delta(T)$ both by choice of material and by lowering the temperature.
3. A maximum possible area of the quantizing circuit S_0 , retaining nevertheless the condition $LI_c < \Phi_0/2$ which is possible by simultaneously decreasing I_c , i.e., increasing the normal resistance of the contacts. In this case there are limitations connected both with the technology and with the action of fluctuations which lead to the total disappearance of superconductivity.^[21]
4. The construction of contacts of such a nature (this still requires detailed clarification) that the volt-ampere characteristics have a form close to (13); this ensures a small amplitude of the oscillations of V(H).

The authors are grateful to I. O. Kulik for assistance in carrying out the theoretical analysis and for useful discussion of the work, and to E. I. Balanov for help in preparing the samples.

¹I. M. Dmitrenko and S. I. Bondarenko, ZhETF Pis. Red. 7, 308 (1968) [JETP Lett. 7, 241 (1968)]; I. M. Dmitrenko, S. I. Bondarenko, Yu. G. Bevza, and L. E. Kolin'ko, Proceedings of the Eleventh International Conference on Low-temperature Physics (St. Andrews) 2, 1968, p. 729.

²S. I. Bondarenko and I. M. Dmitrenko, Coll. Fizika kondensirovannogo sostoyaniya (Physics of the Condensed State) No. 3, 79-94, 1968, Khar'kov, FTINT AN USSR.

- ³ J. Clarke, *Phil. Mag.* **13**, 115 (1966); *New Scientist* **10/III**, 611 (1966).
- ⁴ S. I. Bondarenko, E. I. Balanov, L. E. Kolin'ko, and T. P. Narbut, *PTE* No. 1, 1970.
- ⁵ R. A. Ferrell and R. F. Prange, *Phys. Rev. Letters* **10**, 479 (1963); I. O. Kulik, *ZhETF Pis. Red.* **2**, 134 (1965) [*JETP Lett.* **2**, 84 (1965)].
- ⁶ L. Young, *Anodic Oxide Films*, London, Academic Press, 1961.
- ⁷ L. G. Aslamazov, A. I. Larkin, and Yu. N. Ovchinnikov, *Zh. Eksp. Teor. Fiz.* **55**, 323 (1968) [*Sov. Phys.-JETP* **28**, 171 (1969)].
- ⁸ L. G. Aslamazov and A. I. Larkin, *ZhETF Pis. Red.* **9**, 150 (1969) [*JETP Lett.* **9**, 87 (1969)].
- ⁹ P. G. de Gennes, *Superconductivity of Metals and Alloys*, W. A. Benjamin, 1966.
- ¹⁰ V. Ambegaokar and A. Baratoff, *Phys. Rev. Letters* **10**, 486 (1963); **11**, 104 (1963).
- ¹¹ N. R. Werthamer and S. Shapiro, *Phys. Rev.* **164**, 523 (1967); I. M. Dmitrenko, *Ukr. Fiz. Zh. No. 5*, 1969.
- ¹² I. M. Dmitrenko and Yu. G. Bevza, *Coll. Fizika kondensirovannogo sostoyaniya (Physics of the Condensed State) No. 3*, 70 (1968), Khar'kov, FTINT AN USSR.
- ¹³ A. Th. A. M. De Waele, W. H. Kraan, E. De Bruyn Ouboter, and K. W. Taconis, *Physica* **37**, 114 (1967); **34**, 525 (1967); **32**, 1448, 2044 (1966).
- ¹⁴ D. E. McCumber, *J. Appl. Phys.* **39**, 3113 (1968); W. C. Stewart, *Appl. Phys. Letters* **12**, 277 (1968).
- ¹⁵ Yu. M. Ivanchenko and L. A. Zil'berman, *Zh. Eksp. Teor. Fiz.* **55**, 2396 (1968) [*Sov. Phys.-JETP* **28**, 1272 (1969)].
- ¹⁶ A. H. Silver and J. E. Zimmerman, *Phys. Rev.* **157**, 317 (1967).
- ¹⁷ J. I. Pankove, *Proceedings of the Tenth International Conference on Low-temperature Physics, Moscow*, **2**, 257 (1966).
- ¹⁸ J. E. Zimmerman and A. H. Silver, *Phys. Rev. Letters* **19**, 14 (1967).
- ¹⁹ J. Clarke, *Proceedings of the Eleventh International Conference on Low-temperature Physics, St. Andrews*, **1**, 95 (1968).
- ²⁰ J. Bardeen, *Rev. Modern Phys.* **34**, 667 (1962); V. V. Shmidt, *Zh. Eksp. Teor. Fiz.* **54**, 263 (1968) [*Sov. Phys.-JETP* **27**, 142 (1968)].
- ²¹ T. K. Hunt and J. E. Mercereau, *Phys. Rev. Letters* **18**, 551 (1967).

Translated by Z. Barnea
176