

Inversion of magnetic-impurity oscillations of the photoconductivity in germanium

V. F. Gantmakher and V. N. Zverev

Institute of Solid State Physics, USSR Academy of Sciences
(Submitted June 9, 1976)
Zh. Eksp. Teor. Fiz. 71, 2314–2323 (December 1976)

It is established by experiment that inversion of the magnetic-impurity oscillations of the photoconductivity in germanium (conversion of the photocurrent maxima into minima) can be effected in three ways. At high rates of interband carrier generation, inversion can be obtained by increasing the rate of generation above a certain temperature-dependent critical value G_1 . At low generation rates, inversion sets in when the electric field applied to the sample is increased, or when additional infrared illumination is applied. It appears that the minima of the photocurrent are manifestations of the effect predicted by Elesin, namely the appearance of negative conductivity in crossed electric and magnetic fields in ultraquantum conditions. The appearance of the minima attests to the fact that in all three experimentally realized cases the electron distribution function $f(\epsilon)$ acquires a segment with positive derivative $\partial f/\partial \epsilon > 0$. At large G this can occur, for example, if the recombination is quadratic and its probability increases with decreasing energy ϵ . At low G , the increase of the field or the turning on of the infrared illumination should lead to a depletion of the bottom of the Landau subband, where direct emission of phonons by the electrons is forbidden.

PACS numbers: 72.40.+w

INTRODUCTION

Earlier investigations^[1] of *p*-Ge under conditions of interband photoexcitation at helium temperatures have revealed that the kinetic characteristics (the transverse magnetoresistance, the photomagnetic emf) execute oscillations periodic in the reciprocal magnetic field. It was established that these oscillations are due to periodic changes of the probability of the inelastic scattering of the electrons by neutral acceptors. The probability of such a scattering depends on the ratio of the cyclotron frequency of the electrons in the conduction band $\Omega = eH/mc$ (e and m are the charge and cyclotron mass of the electron, H is the magnetic field) and the energy \mathcal{E} transferred in the scattering; in the case of magnetic-impurity oscillations in germanium, \mathcal{E} is the energy difference between the ground state of the acceptor and the lowest of its excited states. The periodicity of the probability of the inelastic scattering is given by the resonance condition

$$\hbar\Omega(N+\gamma) = \mathcal{E} \quad (N=1, 2, 3, \dots; \quad |\gamma| < 1). \quad (1)$$

The constant γ in (1) is probably due to the dependence of \mathcal{E} on the magnetic field.^[1]

The oscillations make it possible, generally speaking, to separate from the general background the contribution made to the kinetic parameters by one group of carriers—in this case, the electrons. This makes the study of the oscillations of particular interest, since it enables us to trace the kinetic processes that produce this group of carriers. These processes are quite varied. In a number of cases, when the intensity of the interband excitation or the temperature changes, inversion of the magnetic-impurity oscillations sets in, namely, the maxima on their plots are replaced by minima and vice versa.^[1,2]

It appears that inversions are a rather common phe-

nomenon in the kinetics of nonequilibrium processes in semiconductors. They were observed earlier also in the study of other oscillatory effects in semiconductors, e. g., magnetophonon resonance with hot electrons,^[3] and also the study of the spectral dependence of the photocurrent produced by nonequilibrium carriers.^[4]

In a preceding study^[2] we investigated in detail the magnetic-impurity oscillations of the photomagnetic emf. Since, however, the carriers are extremely unevenly distributed in the interior of the sample in the photomagnetic-effect geometry, and furthermore their energy distribution depends on the depth, difficulties arose in the interpretation of the results. It was shown at the same time that in measurements of the transverse photoconductivity, when the photocarriers produced on the surface diffuse along the magnetic field, the carriers fill the volume of the sample uniformly, and the contribution of the carriers having energies higher than the optical-phonon energy can be neglected.

We have therefore undertaken an investigation of oscillation inversion in this simpler case.

EXPERIMENT

The procedure of photoconductivity measurement in a transverse magnetic field was described in detail earlier.^[1] The germanium samples were rectangular plates measuring $4 \times 4 \times 0.3$ mm, and the normal to the surface was parallel to the $[100]$ axis. After treatment with a polishing etchant, contacts of gold wire were welded to the samples. The approximate distance between contacts was 1 mm. The sample was placed directly in liquid helium in the center of a superconducting solenoid. The magnetic field was always parallel to the normal to the sample surface, and the current direction coincided with the (100) axis.

The sample was illuminated with an He-Ne laser (λ

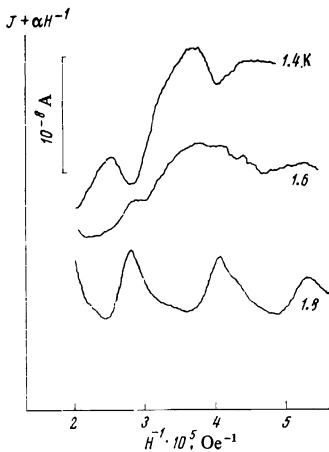

FIG. 1. Inversion of photocurrent oscillations with changing temperature. $G = 2 \times 10^{18} \text{ cm}^{-3} \text{ sec}^{-1}$, $E = 5 \text{ V/cm}$, $\rho = 15 \text{ } \Omega\text{-cm}$.

$= 0.63 \mu$) having an approximate power 30 mW. The light intensity incident on the sample could be smoothly varied by rotating a polarizer. Since the carriers were uniformly distributed over the sample thickness, we shall use as the measure of the light flux the generation rate G , or the number of pairs produced per second in a unit volume. The maximum generation rate in our experiment was $G_{\text{max}} \approx 3 \times 10^{19} \text{ cm}^{-3} \text{ sec}^{-1}$ (lower by one order of magnitude than when a cylindrical lens is used^[1]). It must be stipulated that we did not measure G directly, but calculated it from the laser power; the relative values G/G_0 are much more accurate. A glass plate placed in the liquid helium in front of the sample acted as a filter that cut off the infrared radiation from the warmer parts of the cryostat. By removing this plate we could obtain a combination of surface interband and volume impurity excitations, a procedure used in a number of special experiments.

A dc voltage was applied to the sample, and the photocurrent was preamplified and registered with an x - y recorder as a function of the reciprocal magnetic field. At high generation rates G , when the photocurrent reached 10^{-7} A , it was possible to cancel out the monotonic part of the $J(H^{-1})$ curve, and therefore increase the gain, by applying to the Y coordinate of the recorder a signal proportional to $1/H$ in series with the useful signal.

The magnetic-impurity oscillations of the photoconductivity were investigated in germanium samples doped with gallium, with seven different resistivities ρ at room temperature in the interval from 40 to 2 $\Omega\text{-cm}$, corresponding to acceptor densities N_A from 5×10^{13} to $1.5 \times 10^{15} \text{ cm}^{-3}$. We were unable to observe photoconductivity oscillations in samples with a larger degree of doping ($\rho = 1$ and $0.5 \text{ } \Omega\text{-cm}$; $N_A = 3$ and $6 \times 10^{15} \text{ cm}^{-3}$). The fact that no oscillations occur in samples with $N_A \gtrsim 3 \times 10^{15} \text{ cm}^{-3}$ has already been discussed earlier^[2] and will not be touched upon here.

RESULTS

The possible variable experimental parameters at our disposal were the acceptor density N_A , the temperature T , the rate of interband generation G , and the applied electric field E . In addition, as indicated above, addi-

tional infrared illumination could be applied to the sample.

It turned out that N_A was not an essential parameter for the transverse magnetoresistance when the carriers were uniformly distributed over the sample thickness. All that depended on the degree of doping was the relative oscillation amplitude, which was maximal for samples with resistivities 10 and 15 $\Omega\text{-cm}$ ($N_A = 3$ and $2 \times 10^{14} \text{ cm}^{-3}$), and decreases both with increasing and with decreasing values of ρ . We recall in this connection that N_A was quite sensitive to oscillations of the photomagnetic emf.^[2] For example, the temperature interval in which the oscillations could be observed depended on N_A (see Fig. 4 of^[2]). It appears that the dependence on N_A under conditions when the carriers diffuse across the magnetic field is due to presence of regions with very low carrier density.

Inversion of the photoconductivity oscillations was observed earlier^[1] in the generation-rate interval 10^{19} – $10^{18} \text{ cm}^{-3} \text{ sec}^{-1}$ (see Fig. 8 of^[1]). A detailed investigation has shown that this inversion can be observed not only when the generation rate G changes, but also when the temperature changes (Fig. 1). The critical values G_1 and T are related as follows: the higher the temperature T , the faster the generation rate G_1 at which the inversion takes place (see the upper curve of Fig. 2).

By measuring the temperature dependence of the photocurrent $J(T)$ in a constant magnetic field we were able to establish a correlation between the instant of the inversion of the oscillations of the transverse magnetoresistance and the character of the $J(T)$ dependence. Inversion occurs at the same values of T and G at which the $J(T)$ curves have breaks that separate the regions of strong and weak temperature dependence of the photocurrent (see Fig. 3). The resonances take the form of minima wherever the photocurrent is practically inde-

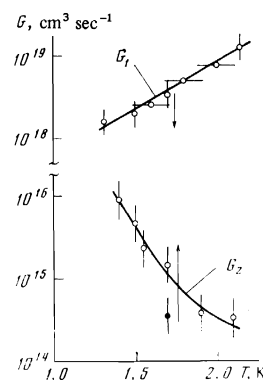

FIG. 2. Connection between the values of G and T at which inversion of the oscillations takes place ($\rho = 15 \text{ } \Omega\text{-cm}$). The points with vertical error bars were obtained from a series of curves with different G at constant T , while the points with horizontal error bars were obtained with different T and constant G (see Fig. 1). The $G_1(T)$ curve is plotted at $E = 5 \text{ V/cm}$. When E is increased, it begins to shift in the direction marked by the arrow. The $G_2(T)$ curve is plotted at $E = 7 \text{ V/cm}$. Its shift with changing field is also shown by the arrow (see the text for details). The black point was obtained at $E = 5 \text{ V/cm}$.

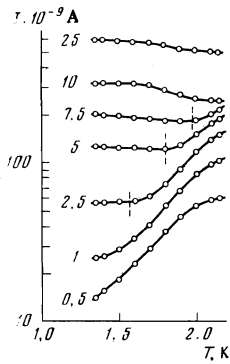

FIG. 3. Dependence of the photocurrent on the temperature at various generation rates. The curves are marked with the values of G in units of $10^{18} \text{ cm}^{-3} \text{ sec}^{-1}$; $H=28.5 \text{ kOe}$, $E=5 \text{ V/cm}$, $\rho=15 \Omega\text{-cm}$. The temperatures at which inversion takes place at the corresponding values of G are marked by vertical dashed lines.

pendent of the temperature, and of maxima in the region where the photocurrent increases strongly.

The relative amplitude A of the oscillations first increases weakly when the generation rate decreases below G_1 , and reaches a maximum value at values of G that range from 2×10^{16} to $2 \times 10^{17} \text{ cm}^{-3} \text{ sec}^{-1}$ for various samples. With further decrease of the generation rate, A decreases and the oscillations disappear at $G \approx 10^{15} - 10^{14} \text{ cm}^{-3} \text{ sec}^{-1}$.

This $A(G)$ dependence occurs only in sufficiently weak electric fields E . At low generation rates, however, even a relatively small increase of the field E again leads to inversion of the oscillations (Fig. 4). The appearance of this second inversion is represented by the $G_2(T)$ curve in Fig. 2. With decreasing E , the $G_2(T)$ curve shifts downward to the level at which the oscillations vanish (i.e., at small values of E the oscillations vanish without undergoing inversion). The upward displacement of the $G_2(T)$ curve with increasing E is limited: in the region $G \approx 10^{17} \text{ cm}^{-3} \text{ sec}^{-1}$ the electric field no longer produces any inversion, and the photocurrent retains the maxima at the resonances all the way to the low-temperature breakdown. (This case was illustrated in Fig. 7 of⁽¹⁾). Finally, at still larger values of G (but somewhat smaller than G_1) the electric field again stimulates inversion and causes the $G_1(T)$ curve to shift downward. This shift is noted in practice in fields of the order of 10 V/cm .

An increase of the electric field leads thus to inversion of the oscillations at low and high generation rates G ; at intermediate values of G , the magnetic-impurity resonances are preserved in the form of maxima,

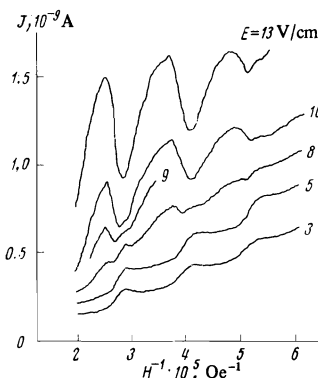

FIG. 4. Inversion of photocurrent oscillations with changing electric field intensity at low values of the light flux. $G=6 \times 10^{15} \text{ cm}^{-3} \text{ sec}^{-1}$, $T=1.4^\circ\text{K}$, $\rho=15 \Omega\text{-cm}$.

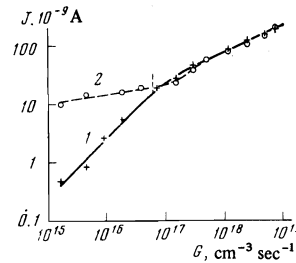

FIG. 5. Effect of infrared illumination of the dependence of the photocurrent on the rate of interband generation: 1—photocurrent without additional illumination, 2—with additional illumination. $T=2.0^\circ\text{K}$, $H=28.5 \text{ kOe}$, $E=5 \text{ V/cm}$, $\rho=15 \Omega\text{-cm}$. The value of G at which oscillation inversion takes place in the presence of IR illumination is marked by the vertical dashed line.

notwithstanding the heating of the electron system, which leads to low-temperature breakdown.

In the experiments described above, only laser light was incident on the sample, and the infrared radiation from the warm parts of the cryostat was filtered out by a glass plate in front of the sample. Without the plate, the shapes of oscillating curves and the values of the photocurrent at large rates G of interband generation remained practically unchanged, and the inversion of G_1 occurred at the same values of G and T as without the infrared illumination. This illumination was significant only at low values of G . Figure 5 shows the dependence of the photocurrent on G at constant H with and without the IR illumination. It is seen that the IR illumination influences strongly the value of J only at $G < 10^{17} \text{ cm}^{-3} \text{ sec}^{-1}$. A second inversion of the oscillations is observed also at the same values of G —at lower generation rates the maxima give way to minima at the resonances in the presence of the IR illumination.

Increasing the electric field, just as in experiments without the IR illumination, shifts the second inversion towards higher values of G . The value of G at which curves 1 of 2 of Fig. 5 diverge also shifts in the same direction.

In addition to leading to inversion, the infrared illumination increases by approximately one order of magnitude the generation rate G_{min} at which the oscillations disappear completely.

DISCUSSION

We start our analysis with the following premises: All the carriers in our experiments are photocarriers—the equilibrium densities of the electrons and holes are negligibly small. Electrons with more energy than the optical phonon play no significant role in the kinetics, since both the combined coefficient of diffusion along the magnetic field H and the combined mobility across H are determined by the electrons with the lower energy. The carriers are uniformly distributed over the depth of the sample. The carrier recombination processes cause in one way or another generation of excited acceptors, either directly or via their ionization with subsequent capture of a hole from the band by the

excited levels. The transitions between the excited states of the acceptors proceed with emission of phonons. At the same time, the probability of the transition of the excited acceptors to the ground state, with spontaneous phonon emission, is so small in germanium that under our conditions these transitions occur mainly in collisions with electrons, so that the observed magnetic-impurity oscillations are due to scattering with energy transfer from the acceptors to the electrons.

These statements were discussed by us in detail earlier.^[1,2] The last of them is the most significant and at the same time the most controversial (see^[2]). The described experiments provide an additional argument in its favor, in view of the appearance of inversion at small G under the influence of an electric field. The point is that the influence of the temperature on the magnetic-impurity oscillations is by itself not an incontestable proof that the oscillations are determined by the cold electrons. Strong temperature dependences of the photoconductivity have been under intensive study in the last few years.^[5,6] Gershenzon *et al.*^[5] have shown that they may be connected with the inclusion of a new recombination channel—via A^+ centers. The temperature then enters in all the kinetic characteristics not via the average kinetic energy of the carriers, but via the probability of the thermal decay of the A^+ centers, i.e., via the number of the recombination centers.

The characteristic energy transferred from the electric field to the electrons, $\Delta\varepsilon \approx eE\Lambda$, is determined by the magnetic length $\Lambda = (c\hbar/eH)^{1/2}$. In fields 7 V/cm, which cause inversion of the oscillations at low generation rates (curve G_2 of Fig. 2), we have $\Delta\varepsilon \approx 0.1^\circ\text{K}$ at $H \approx 40$ kOe, and the heating can be of importance only for cold carriers with low kinetic energy ε in the Landau subband. So small a heat rise should not affect the acceptor system. The inversion of the oscillations in relatively weak electric fields, as well as its dependence on T (curve G_2), confirm therefore that it is precisely the cold carriers that are subject to inelastic scattering with energy transfer \mathcal{E} .

Let us proceed, however, to the oscillation inversion. All the experimental results cited in the preceding section can be fitted well to a single scheme if it is assumed that the maxima of the photocurrent at the resonances are observed, if the electrons have a Boltzmann distribution $f(\varepsilon) = f_0 \exp(-\varepsilon/kT_e)$, in the energy region $\varepsilon \ll \mathcal{E}$ (possibly also with an electron temperature $T_e \neq T$), and that their conversion into minima occurs when their distribution differs greatly from a Boltzmann distribution.

At a Boltzmann function $f(\varepsilon)$, the maxima of the photocurrent at the resonances can be quite naturally attributed to the increase of the collision frequency. Their conversion into minima may be due to specific peculiarities of the conductivity in crossed electric and magnetic fields in the ultraquantum case. According to Elesin,^[7] since the density $g(\varepsilon) \sim \varepsilon^{-1/2}$ of the state in the magnetic subband is a decreasing function of the energy, an electron situated high enough above the bottom of the subband is scattered in elastic and quasielastic collisions predominantly in such a way that its poten-

tial energy increases at the expense of the kinetic energy. The energy conservation law in such collisions taken the form

$$eE\Delta X + \Delta\varepsilon \pm u = 0, \quad (2)$$

where the first two terms represent the changes in the potential and kinetic energies of the electron, ΔX is the shift of the center of the Larmor orbit, and u is the energy of the absorbed or emitted acoustic phonon. (The quantity u is added to (2) in the case of scattering by phonons; the quasi-elasticity condition is then expressed by the inequality $\varepsilon \gg u$.)

For electrons of energy $\varepsilon > eE\Lambda$ the mean value $\overline{eE\Delta X} > 0$. In the case of an equilibrium distribution function this negative contribution to the conductivity is cancelled by the positive contribution of the electrons near the bottom of the subband, in the energy region $\varepsilon \leq eE\Lambda$. However, if for some reason the number of electrons is too small near the bottom of the subband, then the combined conductivity of this group of carriers may turn out to be negative in a strong magnetic field and in an electric field perpendicular to it.

Absolute negative photoconductivity was first observed experimentally in InSb at a distribution function $f(\varepsilon)$ close to a δ function.^[8] It appears that the necessary (but of course not sufficient) condition for its existence is the presence of a distribution-function segment with positive derivative $\partial f/\partial\varepsilon > 0$. This is easiest to demonstrate within the framework of a model in which the electron-system energy-exchange processes are described in the language of electron diffusion in energy space.^[9,10] The energy $(\partial U/\partial t)_E$ drawn from the electric field is given in this model by

$$\left(\frac{\partial U}{\partial t}\right)_E = -\int_0^\infty D_\varepsilon \frac{\partial f}{\partial\varepsilon} g d\varepsilon, \quad (3)$$

where D_ε is the diffusion coefficient along the ε axis, and is determined by the displacements of the center of the Larmor orbit in the collisions.^[10] It is seen from (3) that the inequality $(\partial U/\partial t)_E < 0$ is possible only in the presence of a segment with $\partial f/\partial\varepsilon > 0$. In addition, it is seen that at a given function $f(\varepsilon)$ the integral (3) can be positive for one function $D_\varepsilon(\varepsilon)$, i.e., for one type of scattering center, and negative for another type.

Thus, our assumption concerning the causes of the inversion means that in all three cases—when the generation rate G is increased, when the field E is increased, and when infrared additional illumination is applied at small G —the distribution function acquires a segment with $\partial f/\partial\varepsilon > 0$. It is quite difficult to corroborate this assumption, particularly because there are as yet no theoretical calculations of the processes that govern the distribution function $f(\varepsilon)$ under the particular conditions of our experiments.

This pertains above all to the electron-phonon interaction. Since the translational motion of the electrons in germanium is described at $H \parallel [100]$ by an effective mass $m^* = 1.43m_0$,^[2] while the velocity of the longitudi-

nal sound is $s \approx 5 \times 10^5$ cm/sec, we have $m^*s^2 \approx 2.5$ °K. The condition

$$m^*s^2 > kT \quad (4)$$

means that the thermal velocity $v_T = (kT/m^*)^{1/2} < s$, so that the thermalized electrons are not only incapable of emitting phonons, but their absorption is also subject to definite limitations. This leads to an abrupt decrease of the energy exchange between the electrons and the phonons, an extremely important factor, since it is precisely the phonon system that should receive the energy the electron has during the last stage of its thermalization, as well as the energy acquired by the electron from the electric field. We note that energy exchange within the electron subsystem under these conditions has also been relatively little investigated, since paired electron-electron collisions in a magnetic field $\hbar\Omega > \varepsilon$ do not influence the distribution function (see^[11]).

Our arguments are therefore based mainly on experimental evidence.

Consider the inversion of G_1 first. The most probable recombination channels are binding into excitons and electron capture by A^+ centers.^[5] The probabilities of both processes increase with decreasing ε , since both are based on Coulomb interaction. In addition, both are quadratic-recombination processes (the latter at not too low temperatures). Therefore the number of cold carriers is $n_1 \sim G^{1/2}$, whereas the number of warm carriers that are still being cooled is $n_2 \sim G$. It is clear that when G is increased the thermal electrons begin to exceed in number the cold electrons, $n_2 > n_1$, at the instant when

$$G > G_1 \approx \tau_c \kappa^{-2} \quad (5)$$

where τ_c is the cooling time and κ is the kinetic recombination coefficient and is connected with the lifetime $\tau = (\kappa n_1)^{-1}$. At $G > G_1$ the distribution function may acquire a maximum at an energy determined from the equation $\tau_c(\varepsilon) = \tau(\varepsilon)$.^[12]

Naturally, the nonequilibrium distribution that develops in this case should no longer depend on T . Therefore the presence of breaks on the curves of Fig. 3 confirms the correctness of the proposed explanation. (The weak temperature dependence to the left of the break can be attributed, for example, to changes in the system of the scatterers.)

From this point of view, the effect of the electric field at generation rates $G \lesssim G_1$ also becomes understandable. Heating by the field leads to the same effect (inversion) as lowering the temperature: τ_c can be increased either by turning on the heat and thereby slowing down the rate of electron cooling, or by lowering the final cooling temperature.

The mechanism that distorts the distribution function and leads to inversion under the influence of the electric field at low generation rates G (inversion G_2 , see Fig. 2), is probably somewhat different. Owing to the large value of m^*s^2 the electrons with small ε can give up the energy acquired from the field mainly via electron-exci-

ton or ternary electron-electron collisions. If these collisions are too infrequent, owing to the low excitation concentration, then the electric field should cause an effective depletion of the bottom of the Landau subband.

At faster generation rates, the electron-exciton and electron-electron collisions stabilize the distribution function, cause it to assume a Boltzmann form, and reduce the role of heating to causing the electron temperature T_e to differ from the bath temperature T . Therefore no inversion of the oscillations sets in until low-temperature breakdown occurs.

One might ask why the electron-electron collisions, which effectively mix the electrons in the region $G \sim 10^{17}$ cm⁻³ sec⁻¹, cannot cope with this task at stronger pumps $G \gtrsim G_1$, when the excitation density is higher. The point may be that in these cases the decisive energy intervals are different. At $G \approx G_2$ the electric field distorts the distribution near the very bottom of the subband, whereas at $G \gtrsim G_1$ the distribution function becomes distorted in the region $\varepsilon > kT$.

In the region where curves 1 and 2 of Fig. 5 diverge, the effect of infrared illumination reduces mainly to heating of the carriers produced in interband transitions. This follows from the fact that without the interband light the photocurrent due to the additional infrared illumination is approximately 10^{-9} A, i. e., the photocurrent produced by each of the type of excitation is smaller by an order of magnitude than the current due to their joint action. As seen from the figure, at this instant, too, the inversion sets in at the instant when the heating by the infrared radiation begins to distort the stationary distribution that has become established in the electron system.

Generally speaking, everything said above pertains only to strict resonance $\mathcal{E} = N\hbar\Omega$. In contrast to the case of elastic scattering, considered by Elesin *et al.*,^[7,8] under conditions of inelastic scattering by impurities the energy conservation law takes the form

$$\Delta\varepsilon + eE\Delta X + \mathcal{E} - N\hbar\Omega = 0. \quad (6)$$

At resonance $\mathcal{E} = N\hbar\Omega$, Eq. (6) reduces to Eq. (2). But at a detuning $\Delta = \mathcal{E} - N\hbar\Omega \neq 0$ substantial differences appear. The case of inelastic scattering was considered theoretically by Ryzhii^[13] as applied to a magnetic resonance. He has shown that negative conductivity is possible also in the case of a Boltzmann distribution of the carrier if the effective temperatures T_e of the carriers and of the scatterers T_0 are different. In the case $T_e > T_0$ considered in^[13], negative conductivity sets in at $\Delta < 0$. In our case the acceptor temperature is

$$T_0 = \mathcal{E}/k \ln[(N_A - N^*)/N^*] \gg T_e \quad (7)$$

(N^* is the number of excited acceptors), and a fraction of the energy transferred from the acceptors to the electron system should go into work to overcome the electric-field forces at $\Delta > 0$.

We have no grounds at present for stating that we have observed negative conductivity due to inelasticity of the

scattering. It is possible the observed effect decreases the photocurrent in the intervals between the resonances and thus leads to an increase of the oscillation amplitude.

The authors thank I. B. Levinson for numerous fruitful discussions, E. M. Gershenson and the participants of the seminar under his direction for valuable remarks.

¹V. F. Gantmakher and V. N. Zverev, *Zh. Eksp. Teor. Fiz.* **69**, 695 (1975) [*Sov. Phys. JETP* **42**, 352 (1976)].

²V. F. Gantmakher and V. N. Zverev, *Zh. Eksp. Teor. Fiz.* **70**, 1891 (1976) [*Sov. Phys. JETP* **43**, 985 (1976)].

³M. M. Aksel'rod, V. P. Lugovoi, R. V. Pomortsev, and I. M. Tsidil'kovskii, *Fiz. Tverd. Tela (Leningrad)* **11**, 113 (1969) [*Sov. Phys. Solid State* **11**, 81 (1969)].

⁴E. A. Protasov and A. G. Rodionov, *Fiz. Tverd. Tela (Leningrad)* **16**, 595 (1974) [*Sov. Phys. Solid State* **16**, 387 (1974)].

⁵E. M. Gershenson, Yu. P. Ladyzhinskiĭ, and A. P. Mel'nikov,

Fiz. Tekh. Poluprovodn. **7**, 1100 (1968) [*Sov. Phys. Semicond.* **7**, 746 (1968)].

⁶T. Ohyma, K. Murase, and E. Otsuka, *J. Phys. Soc. Japan* **29**, 912 (1970).

⁷V. F. Elesin, *Zh. Eksp. Teor. Fiz.* **55**, 792 (1968) [*Sov. Phys. JETP* **28**, 410 (1969)].

⁸A. S. Aleksandrov, Yu. A. Bykovskii, V. F. Elesin, E. A. Protasov, and A. G. Rodionov, *Zh. Eksp. Teor. Fiz.* **64**, 231 (1973) [*Sov. Phys. JETP* **37**, 120 (1973)].

⁹I. B. Levinson, *Fiz. Tverd. Tela (Leningrad)* **6**, 2113 (1964) [*Sov. Phys. Solid State* **6**, 1665 (1965)].

¹⁰E. Yamada and T. Kurosawa, *J. Phys. Soc. Jap.* **34**, 603 (1973).

¹¹Sh. M. Kogan, V. D. Shadrin, and A. Ya. Shul'man, *Zh. Eksp. Teor. Fiz.* **68**, 1377 (1975) [*Sov. Phys. JETP* **41**, 686 (1975)].

¹²Yu. P. Ladyzhinskiĭ, *Fiz. Tverd. Tela (Leningrad)* **11**, 2282 (1969) [*Sov. Phys. Solid State* **11**, 1842 (1970)].

¹³V. I. Ryzhiĭ, *Zh. Eksp. Teor. Fiz.* **64**, 643 (1973) [*Sov. Phys. JETP* **37**, 326 (1973)].

Translated by J. G. Adashko

Acousto-optical properties of a nematic-crystal layer with homogeneous orientation

O. A. Kapustina and V. A. Lupanov

Acoustics Institute

(Submitted June 10, 1976)

Zh. Eksp. Teor. Fiz. **71**, 2324-2329 (December 1976)

We investigate the change in the structure and in the optical characteristics of a layer with homogeneous arrangement of the molecules of a mixture of the nematic crystals MBBA and EBBA acted upon by acoustic oscillations of frequency 3.2 MHz. It is shown that such layers can be used as an active element of a device for displaying acoustic information. Photographs are presented of acoustic images obtained with the aid of such a device, the operation of which is based on the effect of light scattering.

PACS numbers: 78.20.Hp, 61.30.+w, 43.85.+f

INTRODUCTION

The effect of acoustic oscillations on the optical properties of thin layers of nematic crystals with homogeneous molecule orientation has been discussed in the literature many times.^[1-3] In this paper we report, for the first time, acousto-optical phenomena in layers with homogeneous orientation and their possible use in devices for the display of acoustic information.

DESCRIPTION OF SETUP

We used a cell in the form of a thin layer of oriented nematic material N-8 (mixture of MBBA and EBBA), sandwiched between an acoustically transparent lavsan polyester film 90 μ thick with a light-reflecting coating on one side and an optically transparent glass plate 2 mm thick and 60 mm in diameter on the other. The homogeneous orientation was obtained by producing a microrelief on the surface of the film. This cell (1) was mounted in the end cover of a water-filled cuvette (2) at a distance 200 mm from an acoustic radiator (3), in such a way that the acoustically transparent surface

faced the radiator (Fig. 1a). The optical part of the installation consists of a light source (4) (LG-36A He-Ne laser or an incandescent lamp), a semitransparent mirror (5), polaroids (6, 7) and a photomultiplier FEU-31A (8). The signal from the photomultiplier was

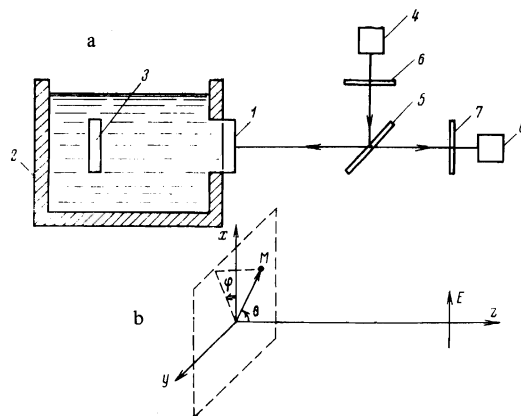

FIG. 1. Block diagram of setup.